

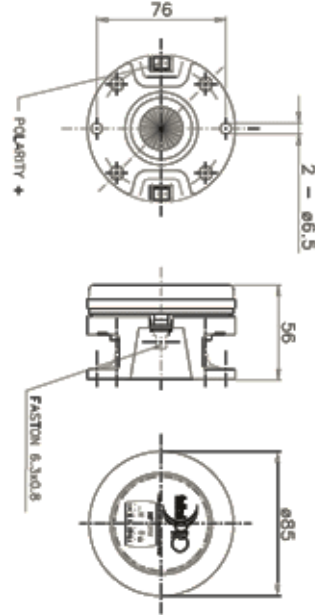

HF10TX Compression Driver



NOMINAL SPECIFICATIONS

Overall Diameter	87 mm (3.4 in)
Depth	56 mm (2.20 in)
180° Mounting Holes Diameter (2xM6)	76 mm (2.99 in)
Net Weight	1.1 Kg (2.43 lb)
Shipping Box	147x130x82 mm (5.79x5.12x3.23 in)
Shipping Weight	1.18 Kg (2.60 lb)
Throat Diameter	25.4 mm (1 in)

ORDERING CODES

Faston Terminals - 8 Ohm Version	00443936
Faston Terminals - 16 Ohm Version	

ELECTRICAL SPECIFICATION

Nominal Impedance	8 ohm
Minimum Impedance	7 ohm
Re	5.5 ohm
Minimum Crossover Frequency *	1.5 kHz
Sensitivity (1W/1m) **	109 dB
Frequency Range	0.8±20 kHz
Nominal Power Handling ***	60 W
Maximum Power Handling ****	120 W
Diaphragm Material	Ketone Polymer
Voice Coil Diameter	44 mm (1.73 in)
Winding Material	Copper Clad Aluminium
Winding Depth	2.30 mm (0.09 in)
Former Material	Kapton
Magnetic Gap Depth	3 mm (0.12 in)
Flux Density	1.9 T

NOTES

Driver mounted on LTH102 horn

PATENT PENDING

(*) 12 dB/oct or higher slope high-pass filter

(**) Averaged within the frequency range

(***) Test made for 2 hours with Pink Noise signal (6 dB Crest Factor) from minimum crossover frequency. Power calculated on rated minimum impedance. Driver mounted on aluminium horn.

(****) Maximum power is defined as 3dB greater than nominal power.

CURVES

